

GP 200 - GP 250

Grappin spécial Grue Camion

- 1 Chape de cardan mâle.
- 2 Version joint-tournant ou rotateur.
- 3 Bâti en acier HLE. Tuyautage intérieur. Vérins intégrés dans les griffes.
- 4 Axes traités HF.
- 5 4 ou 5 griffes en acier anti-abrasion.
- 6 Pointes d'usure.

Options : Cœurs Largeur (a)
Hauteur (b)
Complet (c)

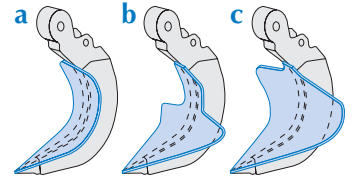

CE



	t	t	l	kg	kg	ø	A	B	C	D	E	F	bar	l/mn	bar	l/mn	t	tm
GP 200	4	4	270	410	515	1500	1100	945	1195	1785	435	1351	200/300	25/55	320 max.	3/5	6/7	8/15
GP 250	6	6	270	435	540	1500	1145	990	1195	1785	435	1351	200/300	25/55	320 max.	7/10	8/10	16/24

kg : Poids avec 5 griffes, sans cardan.

GP 200 - GP 250

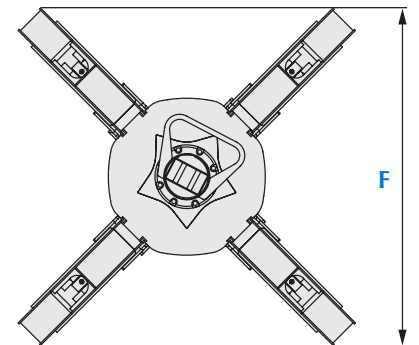
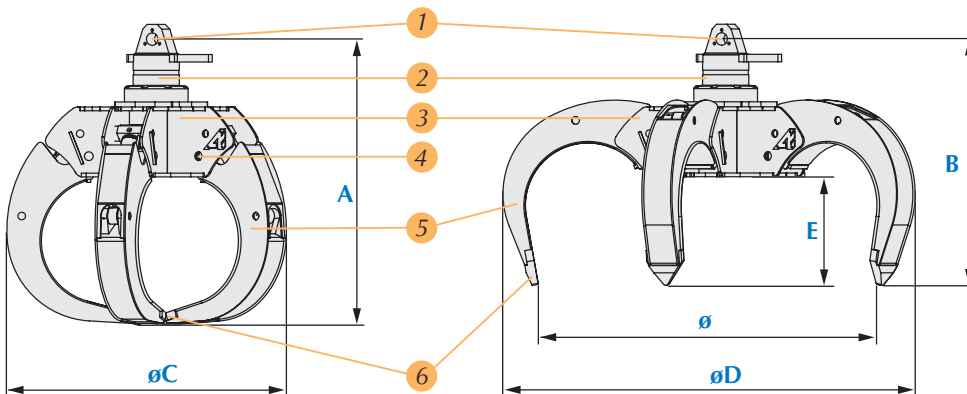

Encombrement version 4 griffes.