

CU 3500

Universal processor with jaws quick change



- 1 Top plate for bolt on bracket.
- 2 Continuous 360° hydraulic rotation.
- 3 Twin reversed cylinders, protected rams.
- 4 Body in high tensile steel.
- 5 Patented jaws quick hitch system (20 minutes).
- 6 Individual jaws stand.
- 7 Specific cinematic of jaws for each use.



		H	O	P	F1	F2	F3	L*	I	IPE	I	IPN	I	HEA				Temps Cycle Total**				
	kg	mm	mm	mm	t	t	t	mm	mm	mm	mm	mm	mm	mm	mm	mm	bar	l/min	sec	bar	l/min	t
CU 3500 BB	3500	2420	900	810	430	155	116	680	-	-	-	-	-	-	60	380	550	4"	140	28/40	38/55	
CU 3500 CF	3350	2300	580	520	416	245	117	310	400	320	260	12	60	380	550	380	550	4"	140	28/40	38/55	
CU 3500 CB	3300	2500	1000	860	476	168	120	170	-	-	-	-	-	60	380	550	380	550	4"	140	28/40	38/55

Weight without top plate.

L* : Jaws width

**Working time for 550 liters without speed valve or 380 liters with speed valve

CU 3500 BB - B

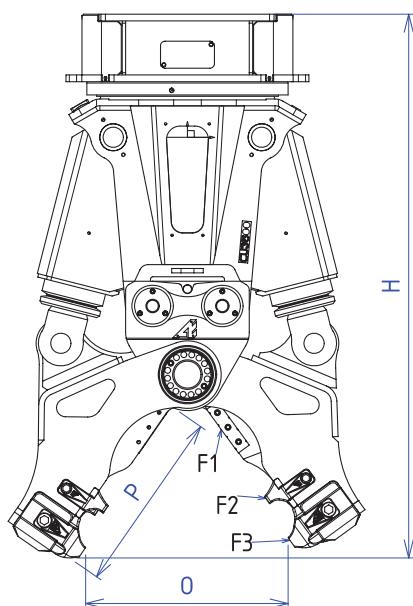

CU 3500 CF

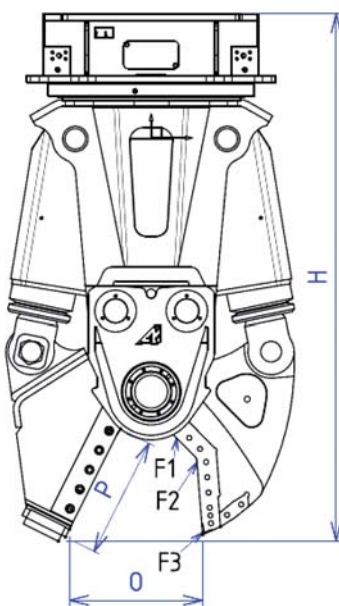

CU 3500 CB

